



**2017 J/105 Chesapeake Bay Championship
October 28-29, 2017**

Organizing Authority: Annapolis Yacht Club
Annapolis, Maryland, USA
Event Website:

<http://www.annapolisyc.com/racing/regattas>

**AMENDMENT #1
to the SAILING INSTRUCTIONS**

SI 10.1 is deleted. is replaced with:

[Reason: Not needed with only the J/105 class participating]

In SI 10.2, "starting mark" is replaced with "starting/finishing mark"

In SI 13, "blue flag" is replaced with "orange flag"

In SI 13, "finishing mark" is replaced with "starting/finishing mark"

SI Attachment 2, Courses, is replaced with the next page.

[Reason: Changing the finish line to be same side of RC as the starting line]

SI ATTACHMENT 2 - COURSES

In the below table, the course designation is followed by the mark rounding order for that course. All marks except 2S are to be rounded to port. If the race committee displays "NO GATE" near the course designation, then mark 2S will not be set. If there is a conflict between the color or shape of a mark below and text of the SI 9 (Marks), SI 9 will govern.

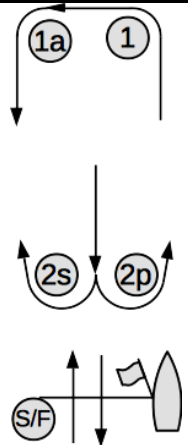
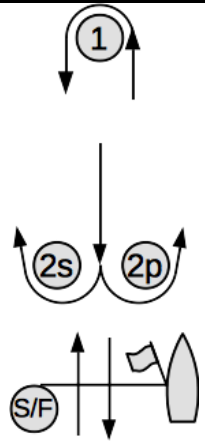
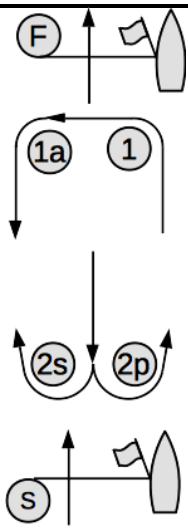
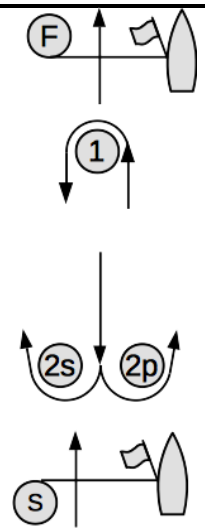
<div style="text-align: center; font-size: 2em; font-weight: bold; margin-bottom: 20px;">LA</div>  <p style="text-align: center;">LA2: Start-1-1a-2s/2p- 1-1a-Finish</p> <p style="text-align: center;">LA3: Start-1-1a-2s/2p- 1-1a-2s/2p- 1-1a-Finish</p>	<div style="text-align: center; font-size: 2em; font-weight: bold; margin-bottom: 20px;">L</div>  <p style="text-align: center;">L2: Start-1-2s/2p- 1-Finish</p> <p style="text-align: center;">L3: Start-1-2s/2p- 1-2s/2p- 1-Finish</p>
<div style="text-align: center; font-size: 2em; font-weight: bold; margin-bottom: 20px;">WA</div>  <p style="text-align: center;">WA2: Start-1-1a-2s/2p- Finish</p> <p style="text-align: center;">WA3: Start-1-1a-2s/2p- 1-1a-2s/2p- Finish</p> <p style="text-align: center;">WA4: Start-1-1a-2s/2p- 1-1a-2s/2p- 1-1a-2s/2p- Finish</p>	<div style="text-align: center; font-size: 2em; font-weight: bold; margin-bottom: 20px;">W</div>  <p style="text-align: center;">W2: Start-1-2s/2p- Finish</p> <p style="text-align: center;">W3: Start-1-2s/2p- 1-2s/2p- Finish</p> <p style="text-align: center;">W4: Start-1-2s/2p- 1-2s/2p- 1-2s/2p- Finish</p>